

KING
INDUSTRIAL 

16" X 20" COMBO LATHE/MILL

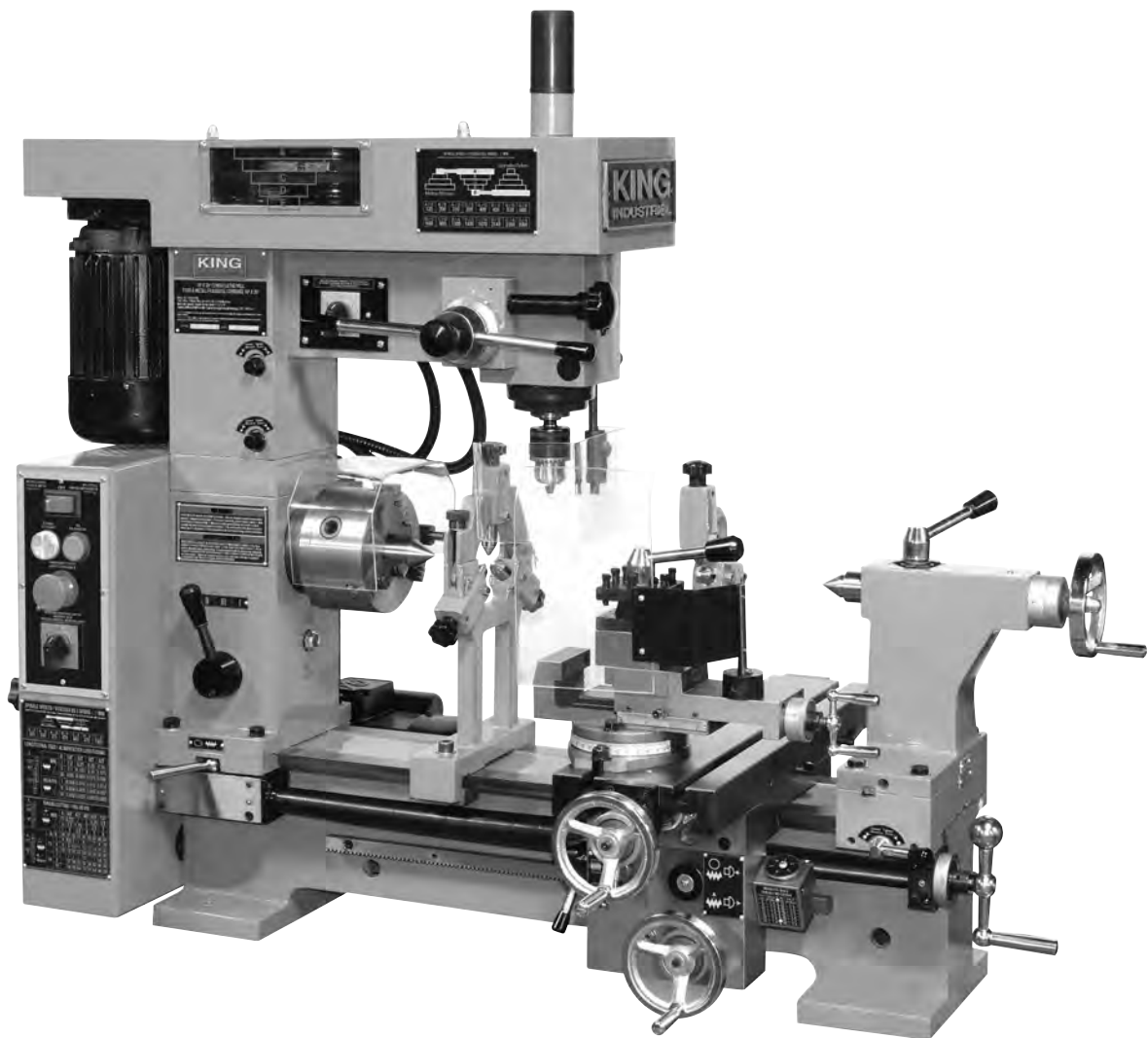

MODEL: KC-1620CLM

INSTRUCTION MANUAL

COPYRIGHT © 2017 ALL RIGHTS RESERVED BY KING CANADA TOOLS INC.



WARRANTY INFORMATION

**2-YEAR
LIMITED WARRANTY
FOR THIS COMBO LATHE/MILL**

**KING CANADA TOOLS
OFFERS A 2-YEAR LIMITED WARRANTY
INTENDED FOR NON COMMERCIAL USE**

PROOF OF PURCHASE

Please keep your dated proof of purchase for warranty and servicing purposes.

PARTS DIAGRAM & PARTS LISTS

Refer to the Parts section of the King Canada web site for the most updated parts diagram and parts list.

LIMITED TOOL WARRANTY

King Canada makes every effort to ensure that this product meets high quality and durability standards. King Canada warrants to the original retail consumer a 2-year limited warranty as of the date the product was purchased at retail and that each product is free from defects in materials. Warranty does not apply to defects due directly or indirectly to misuse, abuse, normal wear and tear, negligence or accidents, repairs done by an unauthorized service centre, alterations and lack of maintenance. King Canada shall in no event be liable for death, injuries to persons or property or for incidental, special or consequential damages arising from the use of our products.

To take advantage of this limited warranty, return the product at your expense together with your dated proof of purchase to an authorized King Canada service centre. Contact your retailer or visit our web site at www.kingcanada.com for an updated listing of our authorized service centres. In cooperation with our authorized serviced centre, King Canada will either repair or replace the product if any part or parts covered under this warranty which examination proves to be defective in workmanship or material during the warranty period.

NOTE TO USER

This instruction manual is meant to serve as a guide only. Specifications and references are subject to change without prior notice.

KING CANADA INC. DORVAL, QUÉBEC, CANADA H9P 2Y4

www.kingcanada.com

GENERAL & SPECIFIC SAFETY RULES



1. KNOW YOUR TOOL

Read and understand the owners manual and labels affixed to the tool. Learn its application and limitations as well as its specific potential hazards.

2. GROUND THE TOOL.

This tool is equipped with an approved 3-conductor cord and a 3-prong grounding type plug to fit the proper grounding type receptacle. The green conductor in the cord is the grounding wire. **NEVER** connect the green wire to a live terminal.

3. KEEP GUARDS IN PLACE.

Keep in good working order, properly adjusted and aligned.

4. REMOVE ADJUSTING KEYS AND WRENCHES.

Form habit of checking to see that keys and adjusting wrenches are removed from tool before turning it on.

5. KEEP WORK AREA CLEAN.

Cluttered areas and benches invite accidents. Make sure the floor is clean and not slippery.

6. AVOID DANGEROUS ENVIRONMENT.

Don't use power tools in damp or wet locations or expose them to rain. Keep work area well lit and provide adequate surrounding work space.

7. KEEP CHILDREN AWAY.

All visitors should be kept a safe distance from work area.

8. MAKE WORKSHOP CHILD-PROOF.

-with padlocks, master switches or by removing starter keys.

9. USE PROPER SPEED.

A tool will do a better and safer job when operated at the proper speed.

10. USE RIGHT TOOL.

Don't force the tool or the attachment to do a job for which it was not designed.

11. WEAR PROPER APPAREL.

Do not wear loose clothing, gloves, neckties or jewelry (rings, watch) because they could get caught in moving parts. Non-slip

footwear is recommended. Wear protective hair covering to contain long hair. Roll up long sleeves above the elbows.

12. ALWAYS WEAR SAFETY GLASSES.

Always wear safety glasses (ANSI Z87.1). Everyday eye-glasses only have impact resistant lenses, they are **NOT** safety glasses. Also use a face or dust mask if cutting operation is dusty.

13. DON'T OVERREACH.

Keep proper footing and balance at all times.

14. MAINTAIN TOOL WITH CARE.

Keep tools sharp and clean for best and safest performance. Follow instructions for lubricating and changing accessories.

15. DISCONNECT TOOLS.

Before servicing, when changing accessories or attachments.

16. AVOID ACCIDENTAL STARTING.

Make sure the switch is in the "OFF" position before plugging in.

17. USE RECOMMENDED ACCESSORIES.

Consult the manual for recommended accessories. Follow the instructions that accompany the accessories. The use of improper accessories may cause hazards.

18. NEVER STAND ON TOOL.

Serious injury could occur if the tool tips over. Do not store materials such that it is necessary to stand on the tool to reach them.

19. CHECK DAMAGED PARTS.

Before further use of the tool, a guard or other parts that are damaged should be carefully checked to ensure that they will operate properly and perform their intended function. Check for alignment of moving parts, breakage of parts, mounting, and any other conditions that may affect its operation. A guard or other parts that are damaged should be properly repaired or replaced.

20. NEVER LEAVE MACHINE RUNNING UNATTENDED.

Turn power "OFF". Don't leave any tool running until it comes to a complete stop.

SPECIFIC SAFETY RULES YOUR COMBO LATHE/MILL

Safety is a combination of common sense, staying alert and knowing how your lathe/mill works. Read and understand the following safety rules before operating.

- 1. AVOID CONTACT.** Make sure no part of tool, tool holder, compound or cross slide, or carriage will come into contact with the chuck during operation.
- 2. PRE-START.** Before starting the machine make sure the workpiece has been properly engaged in the chuck and tailstock center (if in use) and that there is adequate clearance for full rotation.
- 3. HOLDING TOOLS.** Adjust tool holder to provide proper support for the turning tool you will be using. Test tool holder clearance by rotating workpiece by hand before turning lathe ON.
- 4. SPINDLE SPEEDS.** Select the spindle speed which is appropriate for the type of work and material. Allow the lathe/mill to gain its full speed before beginning a cut.
- 5. FEED RATE CHANGES.** Never change feed rate or spindle speeds while the lathe is in motion.
- 6. SPINDLE DIRECTION CHANGES.** Never reverse motor direction while the lathe/mill is in motion.
- 7. STOPPING SPINDLE. DO NOT** stop lathe using your hand against the workpiece or chuck.

- 8. BE ATTENTIVE. DO NOT** leave lathe/mill running unattended for any reason.
- 9. MACHINE CARE AND MAINTENANCE.** Never operate the lathe/mill with damaged or worn parts. Maintain your lathe/mill in proper working condition. Perform routine inspections and maintenance promptly when needed. Put away adjustment tools after use.
- 10. DISCONNECT POWER.** Make sure lathe/mill is turned OFF, disconnected from its power source and all moving parts have come to a complete stop before starting any inspection, adjustment, or maintenance procedure.
- 11. AVOIDING ENTANGLEMENT.** Keep loose clothing articles such as sleeves, belts or jewelry items away from the lathe and drill spindles.
- 12. CUTTING TOOLS.** Always use the proper cutting tools for the material you are turning, make certain they are sharp and that they are held firmly in the tool holder.
- 13. SAFE CHUCK HANDLING.** Always place a board or piece of plywood across the bedway when removing or installing chucks to avoid the possibility of a finger pinch occurring between a loose chuck and the edges of the bedway.
- 14. CLEAN-UP. DO NOT** clear chips by hand. Use a brush, and never clear chips while the lathe is turning.



GETTING TO KNOW YOUR 16" X 20" COMBO LATHE/MILL

- 1) Forward/Reverse switch (Lathe)
- 2) Emergency stop button
- 3) On button
- 4) Power indicator
- 5) Mode selector (Lathe/Off/Mill)
- 6) Mill/drill head locks
- 7) Mill/drill motor
- 8) Forward/Reverse switch (Mill/drill)
- 9) Mill/drill downfeed lever
- 10) Mill/drill fine downfeed knob
- 11) Lathe chuck safety guard/limit switch
- 12) Mill/drill chuck
- 13) Mill/drill chuck safety guard/limit switch
- 14) Tool post safety guard
- 15) Follow rest
- 16) Tool post lock lever
- 17) Tailstock fixed centre
- 18) Mill/drill table
- 19) Tailstock quill lock lever
- 20) Tailstock handwheel
- 21) Leadscrew spring loaded hand crank
- 22) Tailstock lock lever
- 23) Thread chasing dial
- 24) Longitudinal travel handwheel
- 25) Cross slide travel handwheel
- 26) Steady rest
- 27) Lathe 3-jaw chuck
- 28) Bed
- 29) Lathe motor
- 30) Leadscrew/leadscrew protector
- 31) Feed lever
- 32) Feed rate selection lever

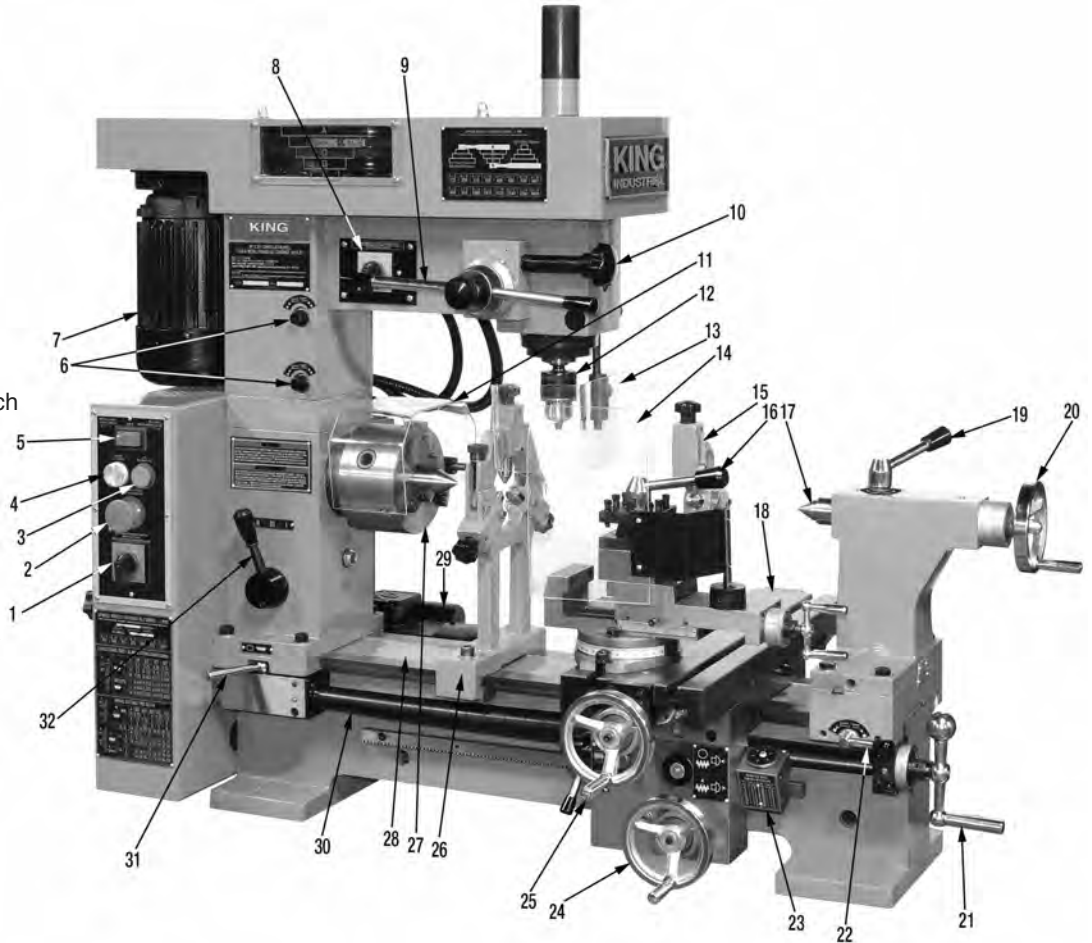

Specifications

| MODEL | KC-1620CLM |
|---|-------------------------------------|
| Distance between centres | 20" |
| Swing over bed & carriage | 16-1/2" / 11-1/2" |
| Spindle bore | 1-1/8" |
| Headstock/tailstock tapers | MT#4 / MT#3 |
| Cross slide travel | 8" |
| Lathe spindle speeds | 7 (160 - 1360 RPM) |
| Thread cutting range | 36 (4 - 120 TPI) 22 (0.2 - 6mm) |
| Automatic feeding range | 0.002 - 0.014" / 0.05 - 0.35mm |
| Drilling/face mill/end mill capacities | 7/8" / 1-1/8" / 3-1/8" |
| Max. distance spindle nose to milling table | 12" |
| Drilling speeds | 16 (125-3000 RPM) |
| Motors (Lathe/Mill) | 3/4 HP, 110V, 9 Amp. 1 phase, 60 Hz |
| Assembled dimensions (LxWxH)/weight | 43" x 19-1/2" x 38" / 515 lbs |
| Package dimensions (LxWxH)/weight | 45" x 23" x 42" / 615 lbs |

ELECTRICAL INFORMATION



WARNING

ALL ELECTRICAL CONNECTIONS MUST BE DONE BY A QUALIFIED ELECTRICIAN. FAILURE TO COMPLY MAY RESULT IN SERIOUS INJURY! ALL ADJUSTMENTS OR REPAIRS MUST BE DONE WITH THE MACHINE DISCONNECTED FROM THE POWER SOURCE. FAILURE TO COMPLY MAY RESULT IN SERIOUS INJURY!

POWER SUPPLY

WARNING: YOUR COMBO LATHE/MILL MUST BE CONNECTED TO A 110V-120V WALL OUTLET, WITH A MINIMUM 15-AMP. BRANCH CIRCUIT AND USE A 15-AMP TIME DELAY FUSE OR CIRCUIT BREAKER. FAILURE TO CONNECT IN THIS WAY CAN RESULT IN INJURY FROM SHOCK OR FIRE.

GROUNDING

Your Lathe/Mill must be properly grounded. Not all outlets are properly grounded. If you are not sure if your outlet is properly grounded, have it checked by a qualified electrician.

WARNING: IF NOT PROPERLY GROUNDED, THIS LATHE/MILL CAN CAUSE ELECTRICAL SHOCK, PARTICULARLY WHEN USED IN DAMP LOCATIONS. TO AVOID SHOCK OR FIRE, IF THE POWER CORD IS WORN OR DAMAGED IN ANY WAY, HAVE IT REPLACED IMMEDIATELY.

If this Lathe/Mill should malfunction or breakdown, grounding provides a path of least resistance for electric current, to reduce the risk of electric shock. This drill press is equipped with a cord having an equipment-grounding conductor and grounding plug. The plug must be plugged into an appropriate outlet that is properly installed and grounded in accordance with all local codes and ordinances.

WARNING: TO MAINTAIN PROPER GROUNDING, DO NOT REMOVE OR ALTER THE GROUNDING PRONG IN ANY MANNER.

110V-120V OPERATION

As received from the factory, your Lathe/Mill is ready to run for 110V-120V operation. This machine is intended for use on a circuit that has an outlet and a plug which looks like the one illustrated in Fig.1.

WARNING: DO NOT USE A TWO-PRONG ADAPTOR(S) FOR THEY ARE NOT IN ACCORDANCE WITH LOCAL CODES AND ORDINANCES. NEVER USE IN CANADA.

EXTENSION CORDS

The use of any extension cord will cause some loss of power. If you do not have a choice, use the table in Fig.2 to determine the minimum wire size (A.W.G-American Wire Gauge) extension cord needed. Use only 3-wire extension cords which have 3-prong grounding type plugs and 3-hole receptacles which accept the tool's plug.

For circuits that are further away from the electrical circuit box, the wire size must be increased proportionately in order to deliver ample voltage to the Lathe/Mill motor. Refer to Fig.2 for wire length and size.

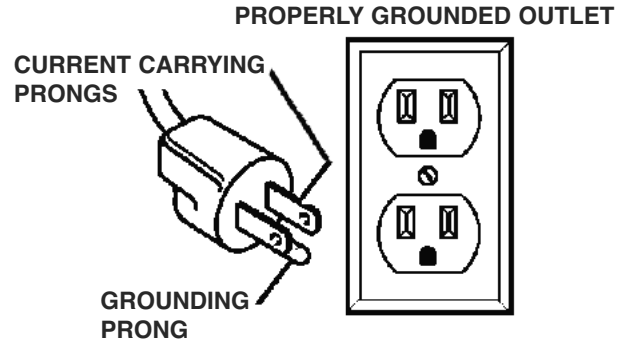

Figure 1

| Tool's Amperage Rating | Cord Size in A.W.G. | | | |
|------------------------|---------------------|----|-----|-----|
| | Cord Length in Feet | | | |
| | 25 | 50 | 100 | 150 |
| 3-6 | 18 | 16 | 16 | 14 |
| 6-8 | 18 | 16 | 14 | 12 |
| 8-10 | 18 | 16 | 14 | 12 |
| 10-12 | 18 | 16 | 14 | 12 |
| 12-16 | 14 | 12 | - | - |

Figure 2



UNPACKING & ASSEMBLY

UNPACKING AND CLEANUP

WARNING! TO REDUCE THE POTENTIAL FOR PERSONAL INJURY AND/OR DAMAGE TO THE MACHINE, BEFORE ASSEMBLING MAKE SURE THE MACHINE IS TURNED OFF. DO NOT TURN ON THE MACHINE UNTIL INSTRUCTED TO DO SO AFTER ALL ASSEMBLY STEPS IN THIS MANUAL HAVE BEEN COMPLETED.

To ensure maximum performance from your Lathe/Mill, clean it properly and install it accurately before use. As soon as you receive the Lathe/Mill, we recommend you follow these procedures:

1. Before lifting machine, remove all bolts locking it to its shipping base.
2. Transport machine using lifting equipment such as a fork lift, hoist or crane. Holes (A) Fig.3 are provided at each end of the bed, insert 3/4" steel bars through these holes and use lifting straps to lift, as shown in Fig.3.
3. Remove the protective coating from the machine and all loose items packed with the machine. The protective coating can be removed with a soft cloth moistened with kerosene.
4. After cleaning, cover the bed surfaces with a layer of good quality paste wax.

NOTE: Do not use acetone, gasoline, or lacquer thinner for this purpose.

OPTIONAL STAND

It is highly recommended to purchase and install Lathe/Mill machine on optional stand (model SS-1620CLM). Please contact your closest King Canada distributor for more information.

INSTALLING HANDLES

1. The leadscrew handle (A) Fig.4 must be installed to the end of the leadscrew. Remove washer and cap screw (B) and then make sure the spring behind the washer stays on the leadscrew. Install handle (A). To use this handle, push it in towards the leadscrew, turn handle while keeping pressure applied.
2. Install the handwheel handles (A, B, C) Fig.5, thread them into the handwheels and secure them using a screwdriver.

3. Install both downfeed handles (A) Fig.6, thread them into the downfeed hub (B).

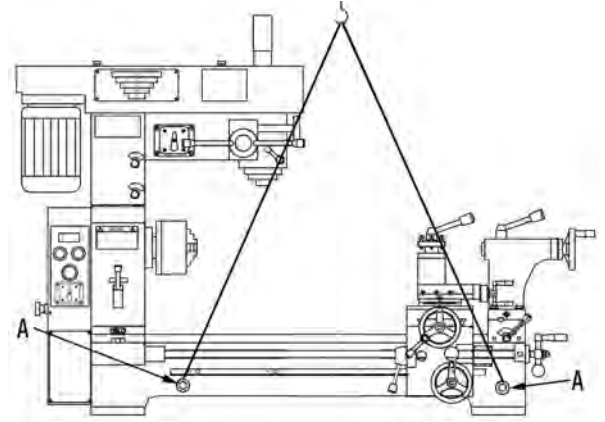

FIGURE 3

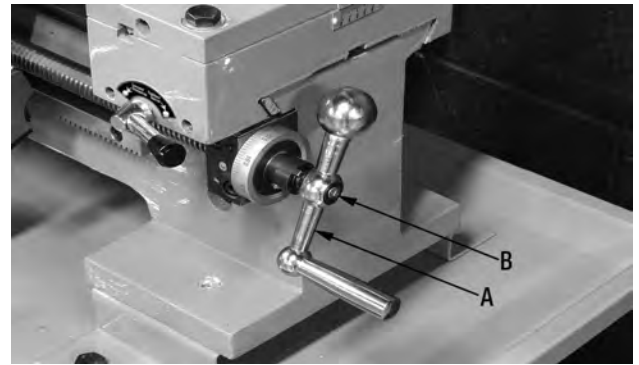

FIGURE 4

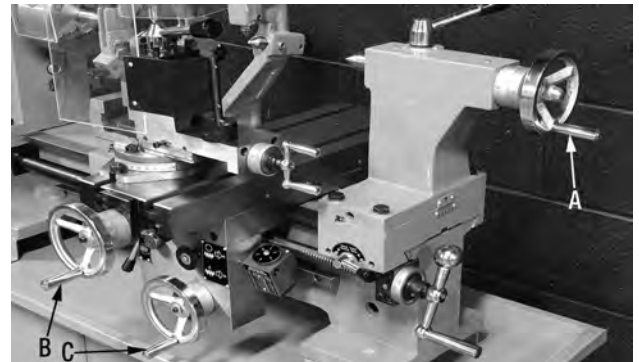

FIGURE 5

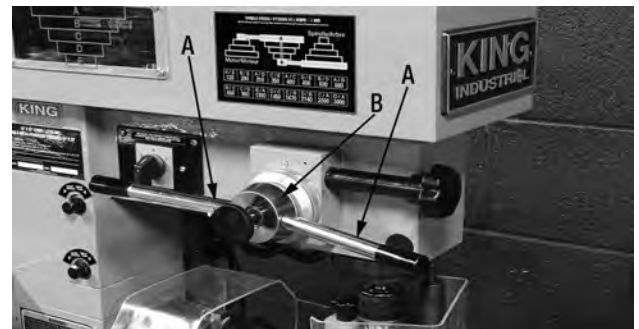

FIGURE 6

METAL LATHE ADJUSTMENTS & OPERATION



BEFORE USING THE METAL LATHE- PIVOT MILL/DRILL HEAD OUT OF THE WAY!

IMPORTANT: Before using this machine in Metal Lathe mode, the Mill/Drill head (A) Fig.7 must be pivoted out of the way towards the rear of the machine to allow for clearance and avoid any form of contact with moving Metal Lathe parts.

Using the supplied key (B), loosen both head locks (C) and pivot the Mill/Drill head towards the rear of the machine as shown in Fig.7. Retighten both head locks (C).

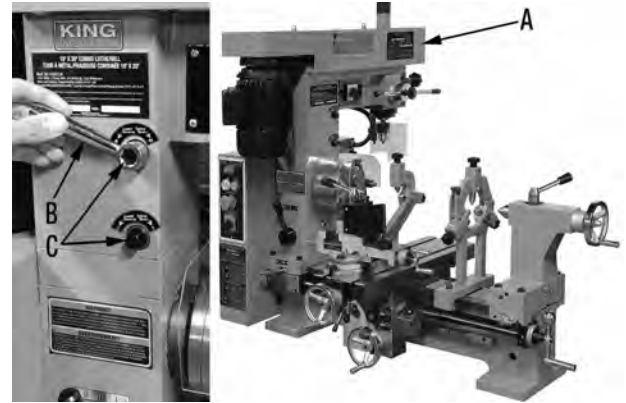

FIGURE 7

CONTROL PANEL

IMPORTANT: The Metal Lathe motor & spindle and the Mill/Drill motor & spindle **can't be used simultaneously.**

Below is a description of each Metal Lathe control button and its function.

Lathe/OFF/Mill Selector Switch (A) Fig.8.-

To operate this machine in the Metal Lathe mode, this switch must be moved to the left to the Lathe position. When machine is not in use, this switch should be placed in the Off centre position.

Power Indicator (B) Fig.8.-

The power indicator lights up when the machine is connected to a power source.

On Switch (C) Fig.8.-

To turn the machine On, press the On button.

Emergency Stop Button (D) Fig.8.-

To stop the machine, push the red emergency stop button (C). Once you push down on the emergency stop button, twist the button clockwise until it pops up, only then will you be able to restart the machine.

Forward/Reverse Switch (E) Fig.8.-

This switch selects the direction of rotation of the Metal Lathe spindle.

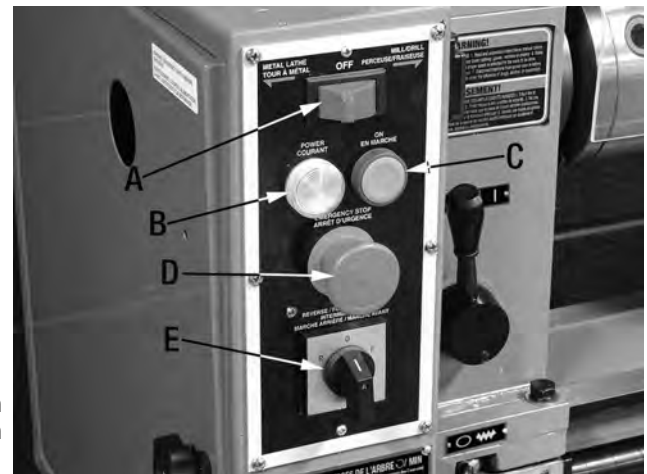

FIGURE 8

METAL LATHE CHUCK REMOVAL/INSTALLATION

How to remove/install Metal Lathe 3-jaw chuck:

1. Make sure the machine is disconnected from the power source.
2. Position a piece of wood under the Metal Lathe chuck, if the chuck was to be dropped the piece of wood would prevent serious damage to the bed or the chuck.
3. The Metal Lathe chuck (A) Fig.9 is secured to a back plate (B). The chuck is held in place with 3 hex. bolts (C). Loosen and remove two of the hex. bolts.
4. Loosen the last hex. bolt, then tap the chuck with a rubber mallet to dislodge the chuck from the back plate. Hold the bottom of the chuck and remove the last hex. bolt. Be careful, the chuck is heavy.
5. To reinstall the chuck, first make sure the surface of the back plate and the chuck are perfectly clean and free of debris.
6. Position one hex. bolt in the back plate and then lift the chuck up to the spindle and align the threaded hole in the chuck with the hex. bolt, do not completely tighten, turn hex. bolt a few turns only.
7. Rotate chuck and install the other two hex. bolts, lightly tighten all hex. bolts keeping the gap even between the chuck and the back plate. Then tighten all hex. bolts to secure the chuck.

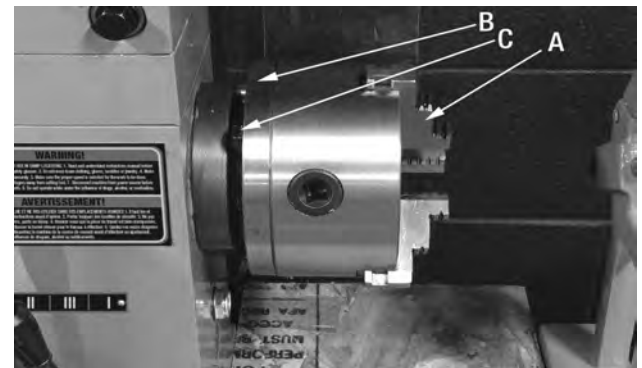

FIGURE 9



METAL LATHE ADJUSTMENTS & OPERATION

TIGHTENING AND CHANGING CHUCK JAWS

The 3-jaw Metal Lathe chuck supplied with this machine comes with 2 sets of jaws, one set of internal gripping jaws (installed) and a set of external gripping jaws.

1. To open or close the jaws of the chuck (A) Fig.10, place the chuck key (B) into the chuck as shown. Turn the chuck key clockwise to tighten the jaws, and counterclockwise to open the jaws.

Important Note: Changing the chuck jaws is straight forward, but PARTICULAR ATTENTION must be given to the sequence in which the jaws are installed.

2. First, remove all 3 jaws from the chuck. This can be done by inserting chuck key (B) Fig.10 into chuck and turning it counterclockwise. Each jaw will move towards the edge of the chuck, once they stop moving they can be removed by hand.
3. Clean the jaws and each chuck slot to make sure there is no debris.
4. Locate the slot in the chuck (A) Fig.11 and the jaw (B) with the #1 markings as shown and rotate the chuck key in the clockwise direction until you see the beginning of the lead thread (C) on the scroll come into view through the slot, then back it off slightly until it disappears again. The lead thread is still showing in the slot in Fig.11. The jaw cannot be loaded until the lead thread for the scroll is no longer seen in the slot.
5. Slide the #1 jaw into the slot and rotate the key clockwise a couple of turns.
6. Repeat step 5 for jaw #2 and #3 in sequence.

USING THE TAILSTOCK

1. Tailstock handwheel (A) Fig.12. Turning this handwheel moves the tailstock quill in or out. The graduated dial (B) on the handwheel is adjustable.
2. Quill lock lever (C) Fig.12. This lever locks the tailstock quill.
3. Tailstock lock lever (D) Fig.12. This lever locks the tailstock to the lathe bed.
4. Offset mechanism. Loosening the four hex. bolts (E) and adjusting screw (F) the tailstock can be adjusted offset from the centre, this allows taper turning operations when a workpiece is held between centres.

INSTALLING/REMOVING DEAD CENTRE IN TAILSTOCK

The dead centre (G) Fig.12 is used to support workpiece that is too long to be supported by only the chuck. Before installing the dead centre, make sure the mating surfaces are very clean.

1. Insert the end of the dead centre (G) Fig.12 into the tailstock quill (H) Fig.12 until it seats.
2. To remove the dead centre, turn tailstock handwheel counterclockwise until the dead centre pops out. Be ready to catch it to prevent it from falling and causing damage.

TOOL POST

This machine comes with a turret tool post (A) Fig.13 which is designed to accept up to four 1/2" cutter tools (B).

1. When more than one tool is secured into the tool post, changing from one tool to another is done quickly by loosening the lock lever (C) Fig.13 and rotating the tool post to the desired cutter. Retighten lock lever once adjustment is made.
2. Secure the cutter with at least two of the fixing bolts (D) on the tool post.
3. Make sure the top of the cutter is at the lathe spindle centre line or just below. The tailstock dead center (E) can be used as a reference, as shown in Fig13.

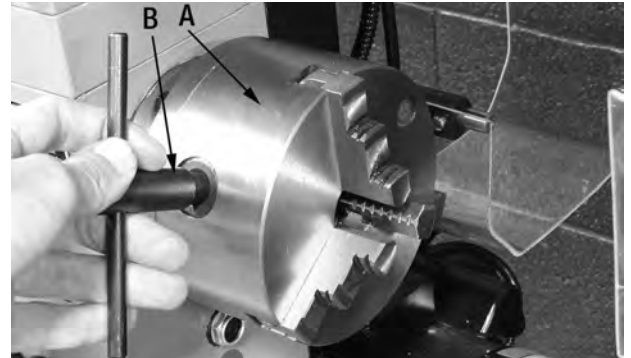

FIGURE 10

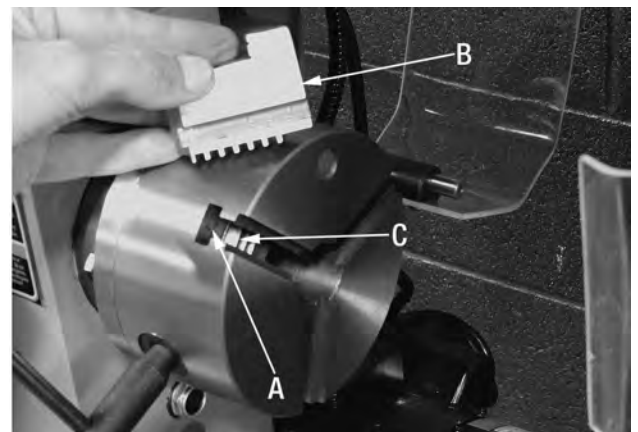

FIGURE 11

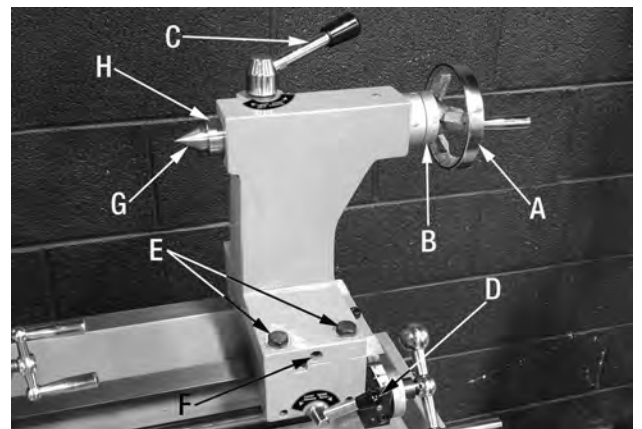

FIGURE 12

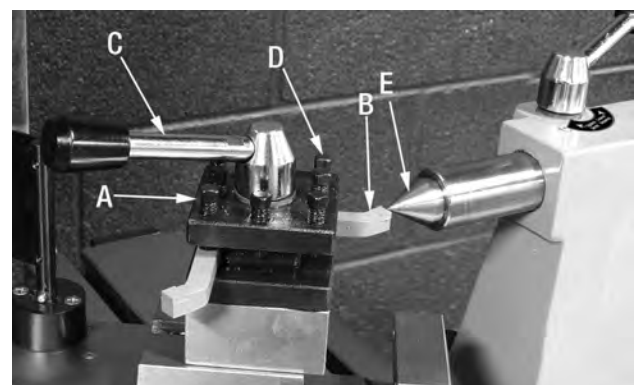

FIGURE 13

METAL LATHE ADJUSTMENTS & OPERATION



CARRIAGE CONTROLS

Compound Slide

1. The compound slide (A) Fig.14 can be adjusted to produce cuts at an angle such as tapered cuts. Loosen hex. bolts (B) at the swivel base of the slide, swivel slide to desired compound angle.

Cross Slide

1. The cross slide (A) Fig.14 moves across the Metal Lathe bed. Turning the cross slide handwheel (C) clockwise moves the slide away from the operator. The motion of this slide is used for facing a workpiece and when advancing a cut for reducing a diameter.

Carriage

1. The longitudinal motion of the carriage (D) Fig.14 is controlled by the lower handwheel (E) or the handle (F) at the end of the lathe bed. The handwheel will be used most often, but when the handle is used, remember that the half nut must be engaged and the handle must be pushed in before it will move the carriage. The motion of this slide is used when cutting along the length of a workpiece. This slide can also be operated with the power feed feature.

Graduated Dials

1. Each handwheel dial (A) Fig.15 can be rotated without turning the handwheel or handle. This is helpful because the dial can be set to zero after the tool touches the part. The graduated dial can be adjusted by holding the handwheel or handle with one hand and turning the dial with the other.

Carriage Lock

1. The carriage lock lever (A) Fig.16 is located as shown in Fig.16. This allows the carriage to be locked for precision facing operations while using the lathe or to make a milling operation more rigid.

FOLLOW REST

The follow rest (A) Fig.17 is used on long workpieces supported by a dead centre mounted in the tailstock. It helps keep deflection to a minimum. The cutter applies some pressure to the part, in the case of thin parts there is a tendency for the part to deflect away from the cutter. The follow rest prevents this from happening, the brass fingers support the workpiece near the point of contact with the cutter.

1. The follow rest (A) Fig.17 gets installed to the leading edge of the carriage as shown.
2. Loosen the adjusting knobs (B) of each brass finger (C) clockwise until they stop.
3. Secure the workpiece in the 3-jaw chuck with a dead centre mounted in the tailstock.
4. Lubricate the brass finger (C) surfaces with oil prior to seating them on the workpiece and occasionally during use.
5. Adjust the brass fingers until they lightly touch the workpiece.

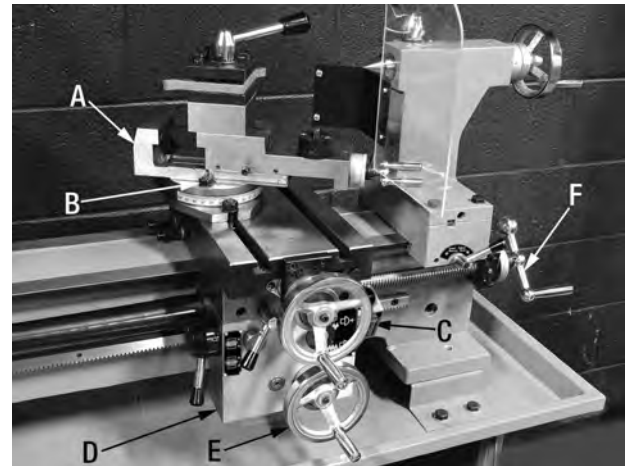

FIGURE 14

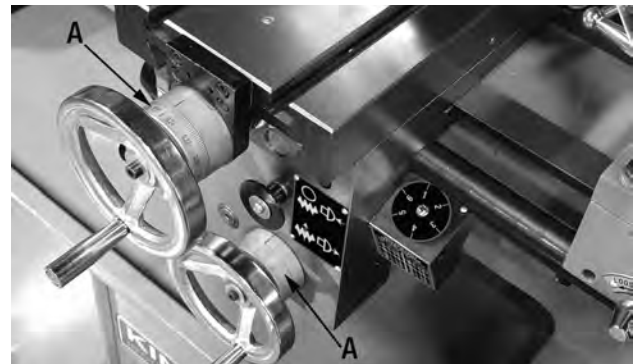

FIGURE 15

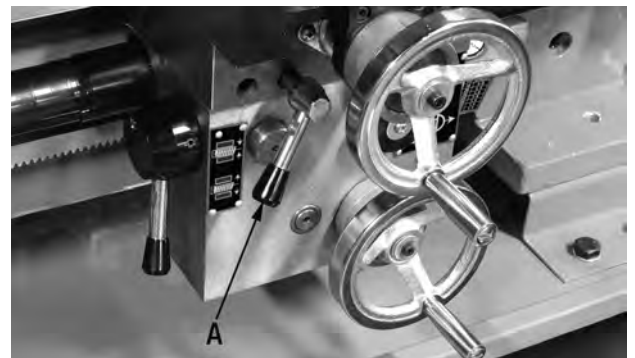

FIGURE 16

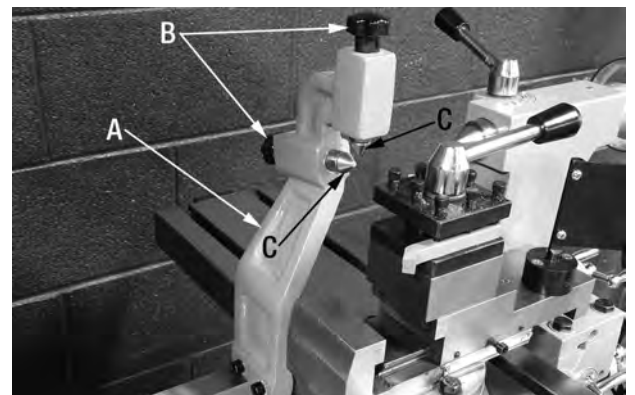

FIGURE 17

METAL LATHE ADJUSTMENTS & OPERATION

STEADY REST

The steady rest (A) Fig.18 is used the same way as the follow rest. It is also used to support workpiece when it can't be supported by the fixed centre in the tailstock.

1. Position the steady rest (A) Fig.18 on the lathe bed in front or behind the carriage.
2. Place the clamp shoe (B) under the steady rest and secure it using cap screw (C).
3. Loosen the adjustment knobs (A) Fig.19 for each brass finger (B) and adjust the brass fingers to allow plenty of clearance for the workpiece.
4. Loosen the knurled knob (C), and pivot the head out of the way.
5. Load the workpiece into the chuck as shown.
6. Oil each brass finger, then pivot the head back into place and secure with the knurled knob (C).
7. Adjust the brass fingers until they lightly touch the workpiece.

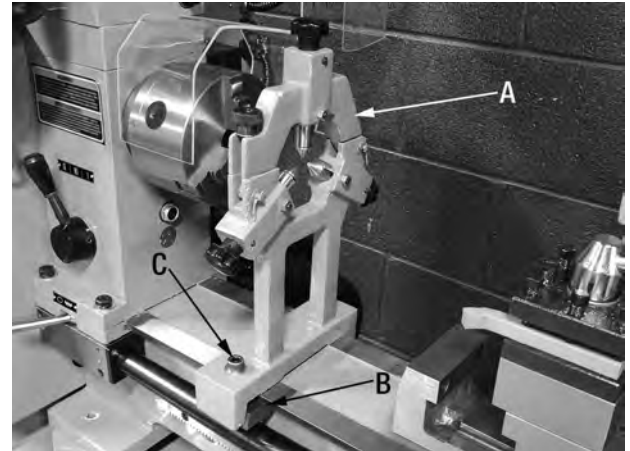

FIGURE 18

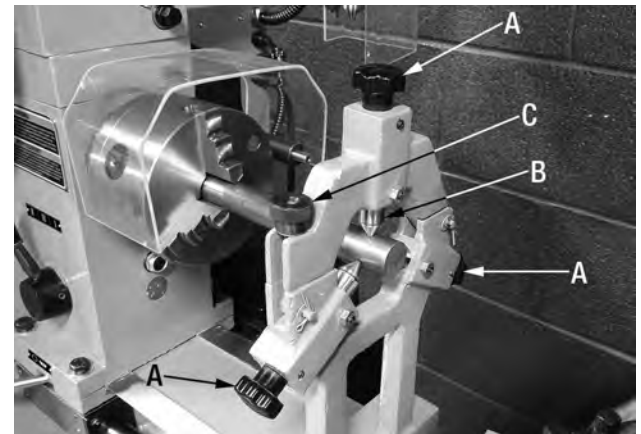

FIGURE 19

METAL LATHE SPEEDS

The speed of the Metal Lathe is controlled by the positions of the V-belts on the pulleys. The chart in Fig.20 shows the combinations of V-belt positions to achieve the range of six Metal Lathe speeds.

To set speed for Metal Lathe/Changing position of V belts:

1. Unplug the machine from the power source.
2. Loosen the belt tension lock lever (A) Fig.21 on the back of the Metal Lathe belt guard (B).
3. Slide the belt tension lock lever down along the slot so the middle pulley releases tension on the belts.

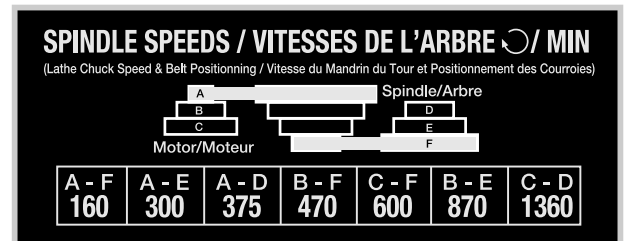

FIGURE 20

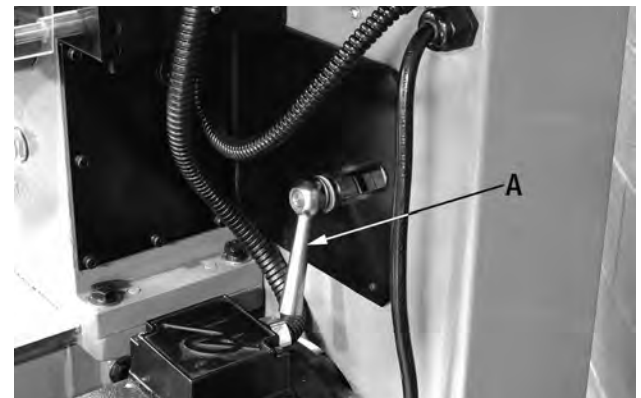

FIGURE 21

METAL LATHE ADJUSTMENTS & OPERATION



METAL LATHE SPEEDS continued...

- To set the Metal Lathe spindle speed to 160 RPM, move the V-belts (A) Fig.22 to the A and F positions on the pulleys as shown in chart Fig.20.
- Raise the middle pulley (B) Fig.22 up the slot to retension the V-belts.
- Tighten the lock lever (A) Fig.21.
- Check the tension of the V-belts. They should deflect 1/2" with moderate finger pressure applied half way between the pulleys. If more deflection is present, retension the V-belts as in Step 5. DO NOT over tension the V-belts.



FIGURE 22

FEED LEVER

The feed lever (A) Fig.23 turns the power feeding feature ON or OFF. When lever is placed to the right, the feed lever engages power to the leadscrew, providing power to the carriage and cross slide.

When lever is placed to the left as shown, the lever disengages the power feed, enabling the carriage to be fed manually with the handle at the end of the lathe bed. The handle cannot be turned manually unless the feed lever is placed to the left.

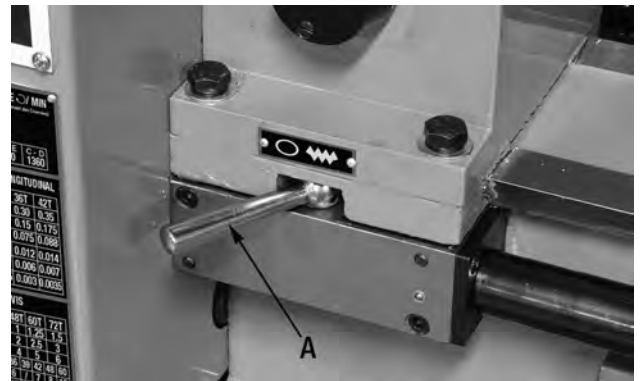

FIGURE 23

FEED SELECTION

WARNING! NEVER MOVE THE FEED SELECTION LEVER WHILE MACHINE IS RUNNING. SERIOUS DAMAGE WILL OCCUR. STOP MACHINE BEFORE ADJUSTING FEED SPEED.

WARNING! NEVER FORCE THE FEED SELECTION LEVER, ROTATE CHUCK BY HAND AND TRY AGAIN.

The feed selection lever (A) Fig.24 controls internal gears that change the feed rate. The coarsest setting for the feed rate lever is in the "I" position. When the lever is turned to the "II" position, the feed rate is reduced by one half of the feed rate of position "I". When this lever is turned to the "III" position, the feed rate is reduced by one half the feed rate of position "II".

Refer to Fig.25 for the powerfeed chart. This chart reflects approximate carriage movement per revolution of the leadscrew. To read this chart:

- The chart shows the required gears and their position required to accomplish the available feed rates.
- The chart shows the available feed rates in millimeters and in inches per revolution.
- The chart shows the feed lever position (I, II, III).



FIGURE 24

Setting a feed rate

Selecting gears for a feed rate of 0.002" per revolution:

- Find 0.002" in the chart in Fig.25.
- Locate the number in gear position A, which is above 0.002". The number in this case is 24, this represents a gear with 24 teeth.
- Look at the column for the feed lever position and find the roman numeral next to the 0.002". In this case III.
- Change the gears at the B, C, & D locations as necessary (see section changing gears for more information).

To make a cut using a feed rate of 0.002" per revolution, install the 24 tooth gear into position A, (see Fig.25) and move the feed selection lever (A) Fig.23 into position III.

| LONGITUDINAL FEED / ALIMENTATION LONGITUDINAL | | | | | | |
|---|--|-----|-------|--------|-------|--------|
| A | | A | 24T | 30T | 36T | 42T |
| | | I | 0.2 | 0.25 | 0.30 | 0.35 |
| | | II | 0.1 | 0.125 | 0.15 | 0.175 |
| | | III | 0.05 | 0.063 | 0.075 | 0.088 |
| | | I | 0.008 | 0.010 | 0.012 | 0.014 |
| | | II | 0.004 | 0.005 | 0.006 | 0.007 |
| | | III | 0.002 | 0.0025 | 0.003 | 0.0035 |

FIGURE 25



METAL LATHE ADJUSTMENTS & OPERATION

HALF NUT

The half nut lever (A) Fig.26 may be engaged and disengaged while the machine is running and while making a cut. Move the lever to the up position to engage the half nut.

Because the threads of the nut and leadscrew will not always be aligned, engaging the half nut may require waiting until they align, with the machine running. Lift the lever upwards. DO NOT force the lever, apply light pressure to the lever and when the threads are aligned the lever will engage.

CARRIAGE POWER FEED

The carriage power feed is designed to aid in cutting threads. Once the proper gears have been installed, (see section Changing gears) and the feed rate have been selected, power to the carriage and cross slide is provided by the leadscrew.

1. To activate the carriage power feed, engage the half nut lever (A) Fig.26 by lifting it upwards.
2. To activate the cross slide power feed, pull on ring (B) Fig.26.

WARNING! Do not attempt to engage both the carriage and cross slide power feeds at the same time, damage to the gears and leadscrew will occur.

CHANGING GEARS

Changing gears is straight forward. Refer to Fig.27 for proper gear selection while following the example below. We will be changing the gears to those that would be used to set the machine for a 0.002" per revolution feed rate. These instructions assume that all of the gears need to be changed. The number of teeth are stamped on each gear.

1. Remove the hex. nuts (A) Fig.28 on the end of the gear shaft of gears A & D.
2. Loosen cap screw (B), at the bottom of the gear support bracket (C) and allow it to rotate downward.
3. Remove the cap screw (D) Fig.28 in the middle of the gears B/C. This will allow removal of the gears and rear bushing (A) Fig.31 supporting them. Remove gears B/C. A T-nut (A) Fig.29 will remain in the gear support bracket as shown.
4. Remove gears A and D in Fig.28.



FIGURE 26

| LONGITUDINAL FEED / ALIMENTATION LONGITUDINAL | | | | | | |
|---|--|-----|-------|--------|-------|--------|
| A | | A | 24T | 30T | 36T | 42T |
| | | I | 0.2 | 0.25 | 0.30 | 0.35 |
| | | II | 0.1 | 0.125 | 0.15 | 0.175 |
| | | III | 0.05 | 0.063 | 0.075 | 0.088 |
| | | I | 0.008 | 0.010 | 0.012 | 0.014 |
| | | II | 0.004 | 0.005 | 0.006 | 0.007 |
| | | III | 0.002 | 0.0025 | 0.003 | 0.0035 |

FIGURE 27

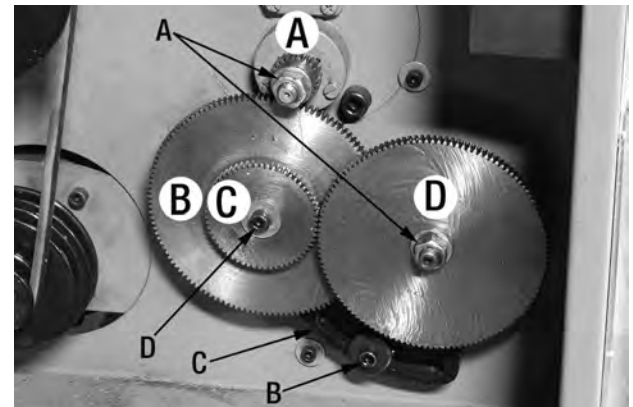

FIGURE 28



FIGURE 29

METAL LATHE ADJUSTMENTS & OPERATION



CHANGING GEARS continued...

5. Replace the gears in positions A and D with 24 and 120 tooth gears as shown in Fig.30.

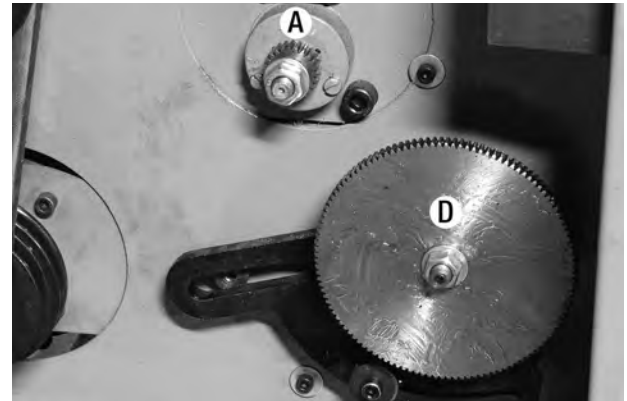

FIGURE 30

6. Insert the rear bushing (A) Fig.31 into the 60/127 tooth gears (B) from the side that has 127 teeth. Align the flats of the rear bushing to the slot in the gear support arm (C) and loosely fasten the assembly to the T-nut (D) using the cap screw (E).

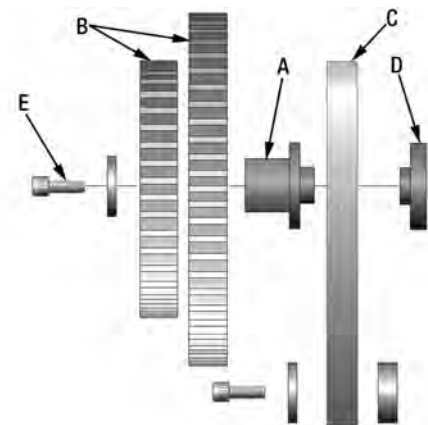

FIGURE 31

8. Rotate the support arm (A) Fig.32 until gears B and A are engaged. Tighten the cap screw (B) at the bottom of the gear support arm. Fig.32 shows the gears properly aligned and engaged.

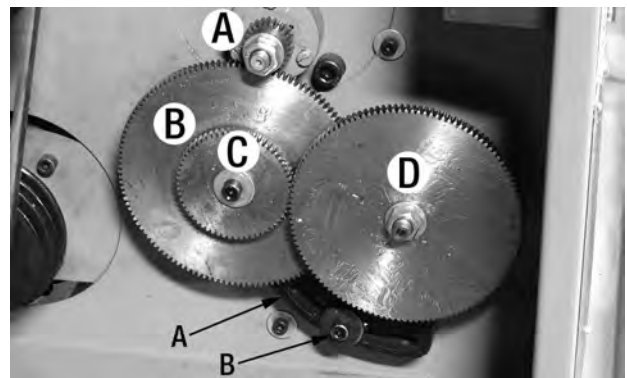

FIGURE 32

INCH TREADING

The inch threading gear chart is shown in Fig.33. This chart identifies the change gears needed for cutting threads with inch pitches (TPI).

1. The numbers below A represent the number of teeth on the gears used in gear position A— in this case 24 or 72 teeth.
2. The column of numbers to the right of D represents the number of teeth on gears used in gear position D.
3. The column below D represents the feed lever position (I, II or III).
4. The gear used in gear position B and C will always be the 120/127 combination gear. The 127 tooth side will be oriented so it is engaged with the gears in the A and D position.
5. The remaining numbers represent the range of possible threads per inch (TPI).

Example: If 5 TPI inch threading is desired, set up the change gears as indicated (120/127, 72, and 30 tooth gear set-up). Refer to Fig.33.

| A / D | 24 | 27 | 30 | 33 | 36 | 39 | 42 | 48 | 60 |
|-------|--------|-----|----|----|----|----|----|----|-----|
| 72 | I 4 | 4.5 | 5 | / | 6 | / | 7 | 8 | 10 |
| | II 8 | 9 | 10 | 11 | 12 | 13 | 14 | 16 | 20 |
| | III 16 | 18 | 20 | 22 | 24 | 26 | 28 | 32 | 40 |
| 24 | I / | / | / | / | 18 | / | / | 24 | 30 |
| | II / | 27 | 30 | 33 | 36 | 39 | 42 | 48 | 60 |
| | III / | 54 | 60 | 66 | 72 | 78 | 84 | 96 | 120 |

FIGURE 33

This above set-up has gearing for cutting a 5, 10, or 20 threads per inch (TPI) screw thread. The feed lever set to the I position will allow 5 TPI. When the feed lever is set to the II position, 10 TPI will be cut and when set to the III position 20 TPI will be cut.



METAL LATHE ADJUSTMENTS & OPERATION

CUTTING THREADS

1. Make sure the thread dial indicator (A) Fig.34 is engaged with the leadscrew. If not, use a hex. key to loosen the cap screw (B) and rotate the thread dial indicator until the gear engages with the leadscrew, then tighten the cap screw to hold the dial in place.
2. Select the RPM you want to use. A slower RPM will give you more time to react especially if threading over a short distance or threading up to a shoulder.
3. Set the forward/reverse switch for either right or left-handed threads.
4. Examine the thread charts (inch or metric), see Fig.33 or 36, and then set the gears to the appropriate settings.
5. Turn ON the spindle to verify settings. Check to see that the leadscrew is turning and verify that the carriage moves in the correct direction by engaging the half nut lever.
6. Once you are confident the settings are correct, disengage the half nut and turn OFF the spindle.
7. Examine the thread dial indicator chart in Fig.35 to determine which numbers (on the thread dial) to engage the half nut.

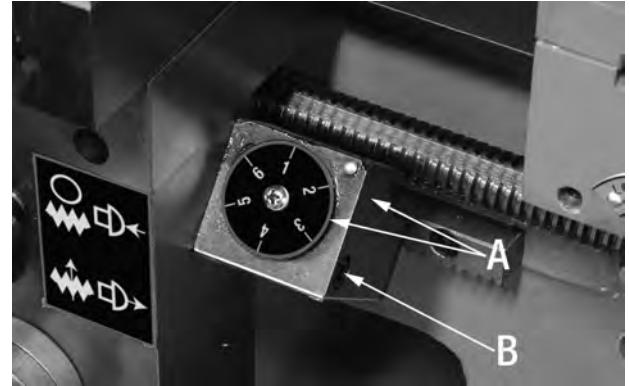

FIGURE 34

Note: There are a total of six marks on the thread dial indicator, ranging 1 to 6. To maintain accuracy and consistency, engage the half nut on the same mark on each pass. Failure to start on the same number each time may lead to cutting off the thread made in the previous pass.

8. If cutting metric threads, you will not use the thread dial. Once the half nut is engaged, you must leave it engaged until the threads are complete.

| INDICATOR TABLE TABLEAU INDICATEUR | | | |
|---------------------------------------|-------------------|-------------|-------------------|
| TPI/ FFP | SCALE/ ÉCHELLE | TPI/ FFP | SCALE/ ÉCHELLE |
| 8 | 1,4 | 18 | 1-6 |
| 9 | 1-6 | 20 | 1,4 |
| 10 | 1,4 | 22 | 1,4 |
| 11 | 1,4 | 24 | 1-6 |
| 12 | 1-6 | 28 | 1,4 |
| 14 | 1,4 | 32 | 1,4 |
| 16 | 1,4 | 40 | 1,4 |

FIGURE 35

METRIC THREADS (MM)

Refer to metric threading gear chart in Fig.36. The chart lists threads in millimeters.

1. The numbers to the right of A represent the number of teeth on gears used in gear position A.
2. The column below A represent the feed lever position (I, II or III).
3. All other numbers show the range of possible metric thread pitches.
4. The 120/127 combination gear do not change and will be the intermediate to gears A and D (24T).
5. Gear D will always have 24 tooth gear installed for metric threading.

| A | THREAD CUTTING / PAS DE VIS | | | | | |
|-----|-----------------------------|------|-----|------|-----|--|
| | 36T | 42T | 48T | 60T | 72T | |
| III | 0.75 | / | 1 | 1.25 | 1.5 | |
| II | 1.5 | 1.75 | 2 | 2.5 | 3 | |
| I | 3 | 3.5 | 4 | 5 | 6 | |

FIGURE 36

Example: To cut a thread with a pitch of 1.25 mm. Install 60 tooth gear in position A, install 24 tooth gear in position D and make sure the 120/127 combination gear is installed in the middle. The 60 tooth gear gets engaged with the 127 tooth gear and the 120 tooth gear is engaged with the 24 tooth gear.

MILL/DRILL ADJUSTMENTS & OPERATION



CONTROL PANEL

IMPORTANT: The Metal Lathe motor & spindle and the Mill/Drill motor & spindle **can't be used simultaneously**.

Below is a description of each Mill/Drill control button and its function.

Lathe/OFF/Mill Selector Switch (A) Fig.37.-

To operate this machine in the Mill/Drill mode, this switch must be moved to the right to the Mill/Drill position. When machine is not in use, this switch should be placed in the Off centre position.

Power Indicator (B) Fig.37.-

The power indicator lights up when the machine is connected to a power source.

On Switch (C) Fig.37.-

To turn the machine On, press the On button.

Emergency Stop Button (D) Fig.37.-

To stop the machine, push the red emergency stop button (D). Once you push down on the emergency stop button, twist the button clockwise until it pops up, only then will you be able to restart the machine.

Forward/Reverse Switch (E) Fig.37.-

This switch selects the direction of rotation of the Mill/Drill spindle.

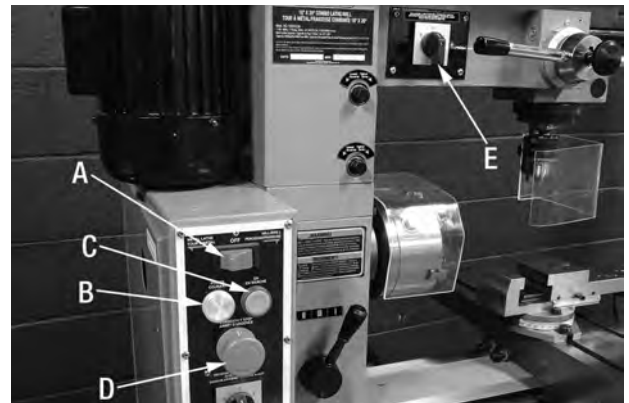

FIGURE 37

MILL/DRILL SPEEDS

The speed of the Mill/Drill spindle is controlled by two V-belts mounted between three pulleys. The belts and pulleys are accessed by removing the upper belt guard as shown in Fig.38.

The spindle speed chart in Fig.39 shows various combinations of V-belt positions for achieving one of the 16 speeds.

To change belt position (to obtain a spindle speed of 125 RPM):

1. Unplug the machine from the power source.
2. Remove the upper belt guard as shown in Fig.38 and loosen both hex. bolts (A).
3. Move the motor assembly (B) to release belt tension. Remove the belts (C) from their current location and reposition them in the desired positions (to get 125 RPM, set belts in A/E positions as shown in chart Fig.39).
4. Move motor assembly to retension the belts and retightening both hex. bolts (A).
5. Reinstall the upper belt guard.



FIGURE 38

SPEEDS / VITESSES DE L'ARBRE \odot / MIN
(M/D) Chuck Speed & Belt Positioning / Vitesse du Mandrin de la Fraiseuse/Perceuse et Positionnement des Courroies

Spindle/Arbre

| | | | | | | | |
|-----|-----|------|------|------|------|------|------|
| A/E | B/E | A/D | C/E | A/C | D/E | B/D | A/B |
| 125 | 200 | 310 | 350 | 400 | 450 | 530 | 600 |
| B/C | C/D | B/A | D/C | C/B | D/B | C/A | D/A |
| 660 | 900 | 1380 | 1450 | 1670 | 2140 | 2350 | 3000 |

FIGURE 39

ROTATING HEAD

The Mill/Drill head can be rotated 90° in both directions. To rotate the head:

1. Unplug the machine from the power source.
2. Loosen the head locks (A) Fig.39 by using the supplied key (B).
3. Rotate the head to the desired position.
4. Retighten the head locks.



FIGURE 40



MILL/DRILL ADJUSTMENTS & OPERATION

QUILL LOCK LEVER

The height of the Mill/Drill spindle can be locked with the quill lock lever (A) Fig.41. Set the desired height of the spindle, and then lock the spindle with the quill lock lever.

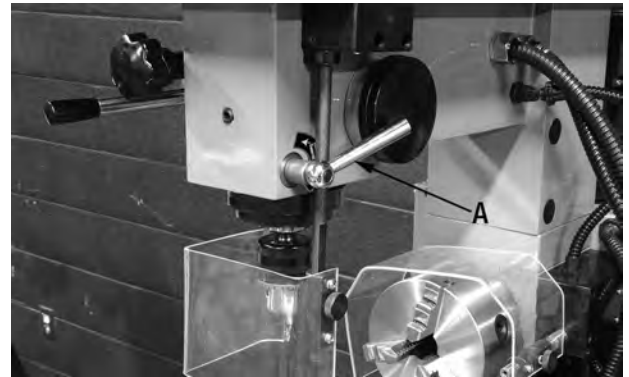

FIGURE 41

FINE DOWNFEED

The up and down motion of the Mill/Drill spindle is controlled by the downfeed handles (A) Fig.42 just like a drill press. But unlike most drill presses, this machine is also supplied with a fine feed knob (B).

To use this feature, rotate the downfeed handles (A) Fig.42 while pressing the knob (C) in the center of the hub (D). The knob will engage and the spindle will no longer move using the downfeed handles. Rotating the fine feed knob (B) in a clockwise direction will cause the spindle to go down slowly. To disengage this feature, rotate the fine feed knob and pull on the knob in the center of the hub.

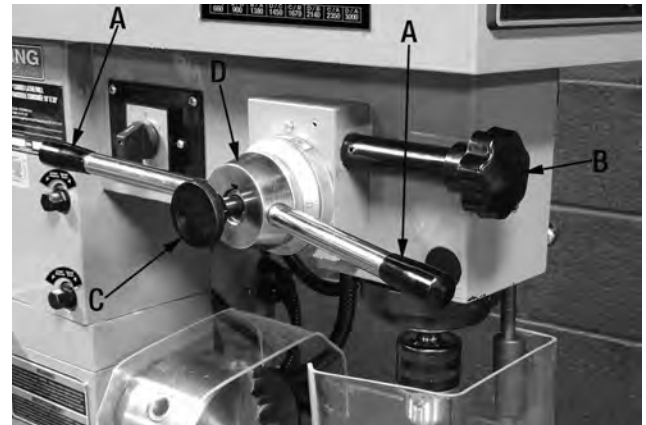

FIGURE 42

WISE & OPTIONAL ELEVATING BLOCK (KM-124)

This machine comes with a vise (A) Fig.43 that also serves as the compound slide for Metal Lathe operation. The 4-way tool post and the tool post safety guard must be removed before using the vise. To open or close the vise jaw, turn handwheel (B).

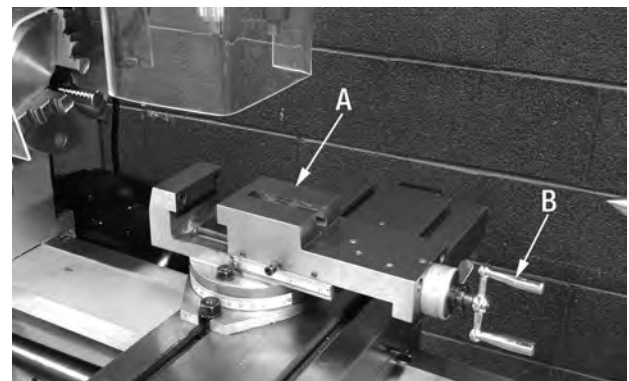

FIGURE 43

An optional Elevating block (A) Fig.44 is available (model KM-124), the vise (A) Fig.43 must be completely removed. The Elevating block gets installed to the cross slide T-slots as shown with the same t-bolts and hex. nuts (B) Fig.44 used to secure the vise.

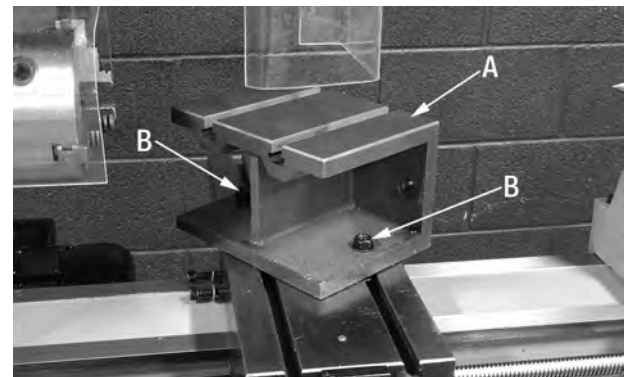

FIGURE 44

MILL/DRILL ADJUSTMENTS, OPERATION & MAINTENANCE



REMOVING/INSTALLING CHUCK

The Mill/Drill chuck and arbor come installed on the spindle from the factory. To remove and reinstall the assembly, follow these instructions:

1. Unplug the machine from the power source.
2. Remove the small plastic cap on top of the belt guard as shown. The draw bar (A) screws into the arbor. Hold onto the outside of the chuck with your free hand, unscrew the draw bar (A) 3 turns only. Three turns is all that you need, any more and the threads on the draw bar and the arbor will be damaged when hitting the end of the draw bar with a rubber mallet. Any less and the arbor does not have enough room to pop loose from the spindle.
3. Tap the end of the draw bar with a rubber mallet. DO NOT use a steel hammer! Damage to the draw bar and hammer, such as chipping, may occur.
4. Once the arbor is loose, hold the chuck with one hand and unscrew the arbor with the other.
5. To reinstall the chuck, first clean the arbor thoroughly. Insert the arbor half way into the spindle, then quickly slide it in place to seat the two tapers together.
6. Reposition the draw bar (A) Fig.45 and thread it into the arbor. DO NOT over tighten! The draw bar only needs to be lightly tightened. The taper is what holds the two parts together, the draw bar just keeps them from chattering loose.



FIGURE 45

MAINTENANCE

WARNING! TO REDUCE THE POTENTIAL FOR PERSONAL INJURY MAKE SURE THE MACHINE IS TURNED OFF BEFORE PERFORMING ANY MAINTENANCE OPERATIONS.

REGULAR MAINTENANCE CHECKLIST

1. Make sure that everything has been installed properly. Check to make sure that all parts are secured properly before using the machine.
2. Keep the machine clean, and regularly clear the machine of sawdust and debris.
3. Make sure you are wearing proper attire for operating machinery. This includes safety glasses, and hearing protection. Avoid loose-fitting clothing, jewelry such as watches or bracelets, or anything that could be caught by moving parts (either the machine itself or the workpiece).

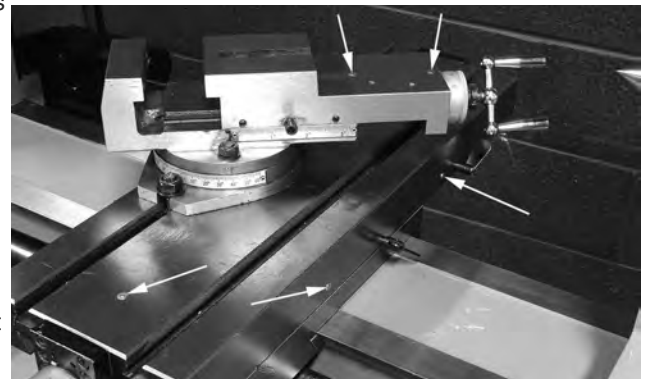

FIGURE 46

LUBRICATION

This machine will function best when it is clean and well lubricated. Take the time to wipe down and oil the machine before each use. We recommend using SAE 20W non-detergent oil unless otherwise specified.

Carriage and Cross Slide: Apply lubrication directly to the oil ports of the carriage and cross slide. See Fig.46.

Motor: The bearings used in the motor are shielded and lubricated for life, therefore, no lubrication is necessary.

Leadscrew: Be sure to clean and lubricate the leadscrew.

Headstock Gearbox: The oil in the headstock should be changed after the first 2 hours of use, then every 6 months, depending on usage. We recommend using a light weight, non-detergent oil. Viscosity can range from 10W to 30W and may include multi-viscosity oil in this same range.

To remove the oil in the gear box, remove the change gear directly under the spindle, remove the cap screw (A) Fig.47, and place a can under the drain hole to collect the waste oil. Remove oil fill cap (A) Fig.48 and fill gearbox until the oil level reaches the centre point of the oil level (B).

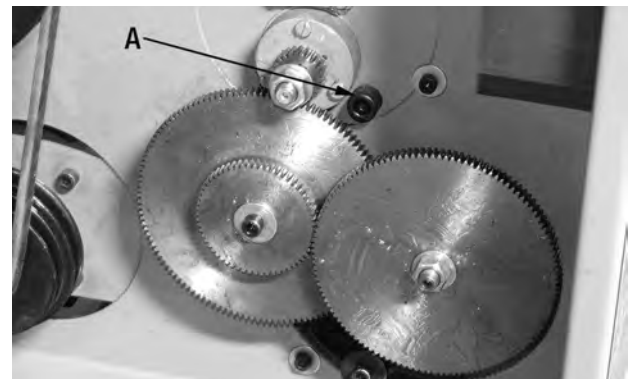

FIGURE 47

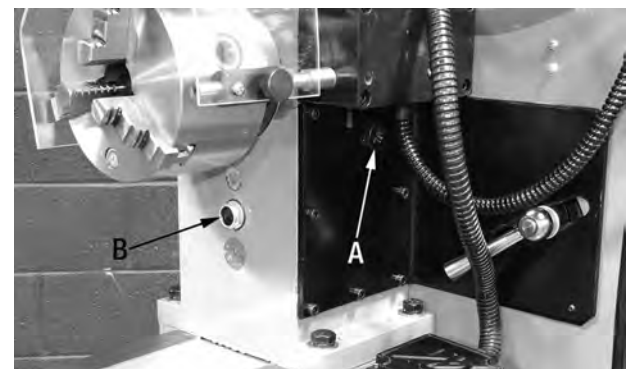

FIGURE 48



MAINTENANCE

LUBRICATION continued...

Tailstock: The tailstock is fitted with 2 oiling ports (A) Fig.49. The tailstock quill (B) may be oiled directly. Apply oil each week or after every five uses (depending on the frequency of operation).

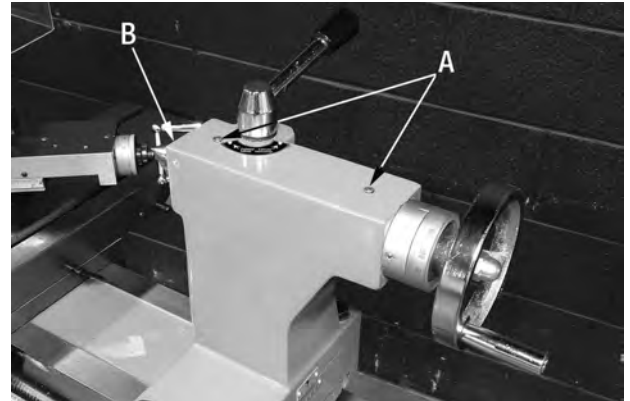

FIGURE 49